

Process Control System

Have greater control over your operation!

- Better manage your treatment costs
- Produce management reports
- Interface with your accounting system

Designed and developed by Osmose engineers, the Osmose Process Control System (PCS) has been designed to meet the requirements of customers who demand the highest level of process control and information management.

PCS Key Features

- The Osmose PCS can be fully customised to suit your unique operation
- Full automation or manual override
- Detailed charge by charge information including reconciliations
- Detailed process information
- Interface with inventory control and accounting systems
- Security and access protocols
- PCS can manage up to three treating cylinders simultaneously
- 24 hour phone support and remote log-in
- Flexible system allows new formulations and or process cycles to be added or modified at any time
- Automated backup system
- Data search function

Osmose PCS is suitable for use with all Osmose high & low pressure preservative systems including:



- **Only top quality components...**
are used to automate your treatment plant.

- **Two PC's ...**

are used in a network, in case one PC fails the other one can continue to run your plant.

- **Uninterrupted Power Supply (UPS) and surge protection ...**

is always installed to minimise interruption.

- **User friendly ...**

and easy to learn interface.

- **Touch screens ...**

are optional.

- **Safety system ...**

logs all plant actions and alarms.

- **Emergency notification ...**

with telephone or paging system.

- **Automatic mix system ...**

calculates chemical additions – then controls the additions with a single button click.

- **Tank circulation can be automated ...**

can be left running as it will pause when the tank is in use for treating.

Training:

On-site training will be supplied by your Osmose® Territory Manager. Back-up and support is just a phone call away as most questions should be able to be dealt with over the phone. Our representatives are also able to provide on-site assistance during our service calls.

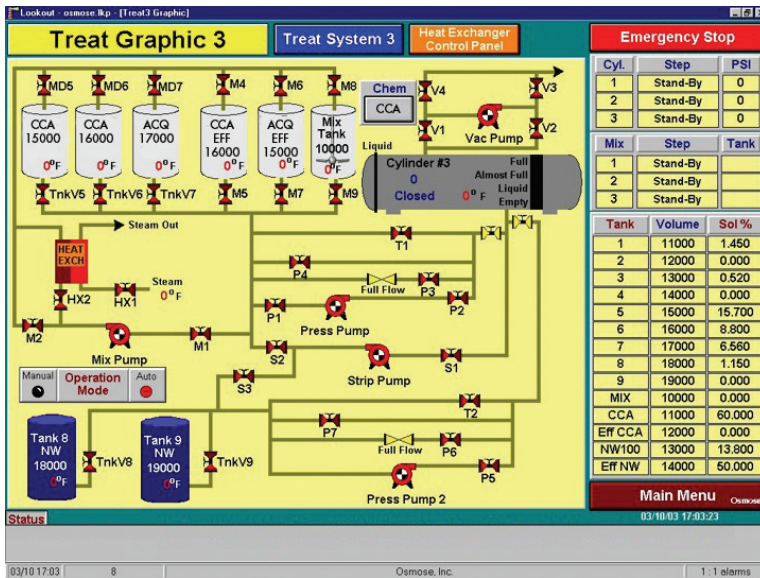

Example of a treatment charge in progress

Charge Report

Charge: 1066 Date: 15/07/2007 11:30:21 Operator: 11119
Plant No.: 1 Address: _____ Tank: 1 (41,150)
Chemical: CCA Hazard Class: H3 Turn Around Time (min): 25 Treatment: H3 300 litres 1.54%
Target Addition: 8.45 Cylinder: 1 # of Samples Taken: 0
of Samples Failed: 0

Time	Min	Max	Act	Min	Max	Act	Min	Max	Act	Min	Max	Act	Min	Max	Act	Reason	
Initial Volume	0	10	3	0	-45	-45	0.0	0.0	0.0	0.0	0.0	0.0	0.0	0.0	0.0	Pressure	
Fill	13	14	13	0	-45	-45	0.0	0.0	0.0	0.0	0.0	0.0	0.0	0.0	0.0	Full	
Press Press	0	15	8	0	1,260	1,604	0.0	0.0	404.2	0.0	0.0	0.0	0.0	0.28	0	Pressure	
Pressure	0	7	7	0	1,400	1,402	0.0	480.0	484.0	0.0	4.40	4.42	0.00	0.00	0.02	0	Time
Press Relief	0	10	2	0	1,900	507	0.0	0.0	423.7	0.0	0.0	5.00	0.00	0.00	0.00	1	Pressure
Empty	0	30	7	0	0	-2	0.0	0.0	448.3	0.0	0.0	0.0	0.0	0.0	0.0	0	Empty
Final Volume	0	25	25	0	-45	-19	0.0	390.0	474.7	0.0	3.20	3.26	0.00	0.00	0.00	0	Time
Final Empty	0	2	4	0	-5	-2	0.0	0.0	306.2	0.0	0.0	4.33	0.00	0.00	0.00	0	Empty
Final	0	2	2	0	-5	-2	0.0	0.0	283.3	0.0	3.07	3.07	0.00	0.00	0.00	0	Time

Printed on: 15/07/2007 11:30:51 Plant Number: 1 Charge Number: 1066 Page 1 of 1

Example of a charge sheet

Osmose Australia
Customer Support 1800 088 809
www.osmose.com.au